

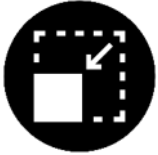

SONCEBOZ

► Torque Motor

4246



COMPACTNESS



ROBUSTNESS



LONG LIFETIME

- Working angle 75° max
- Positioning time < 100 ms
- Weight 430 g
- Peak torque @ 13.5V .. 720 mNm

This actuator is a contactless direct drive device and exhibits both high torque and dynamics.

► Technical data

Resistance [Ω]	Inductance [mH]	Torque constant [mNm/A]	Motor constant [mNm/√W]	Detent torque [mNm]	Sensor signal
2.4	25	125	80	40	Programmable: - Analog: 0.5 to 4.5 V - Digital: PWM / SENT

► Dimensions

Drawing not to scale. All dimensions in mm.

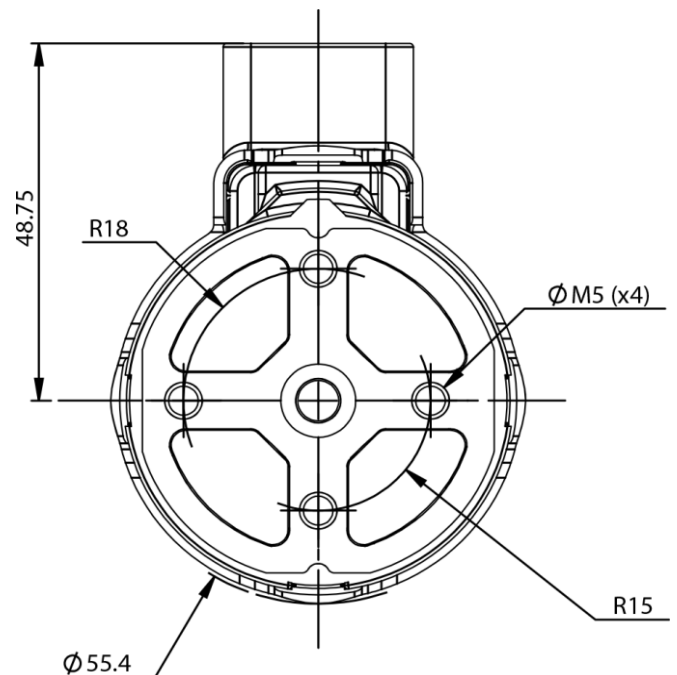
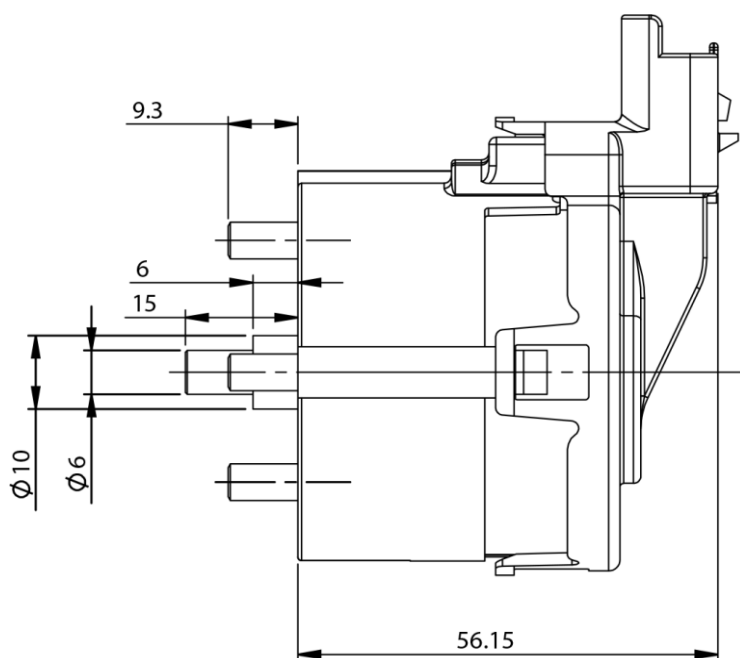

► Dynamic characteristics

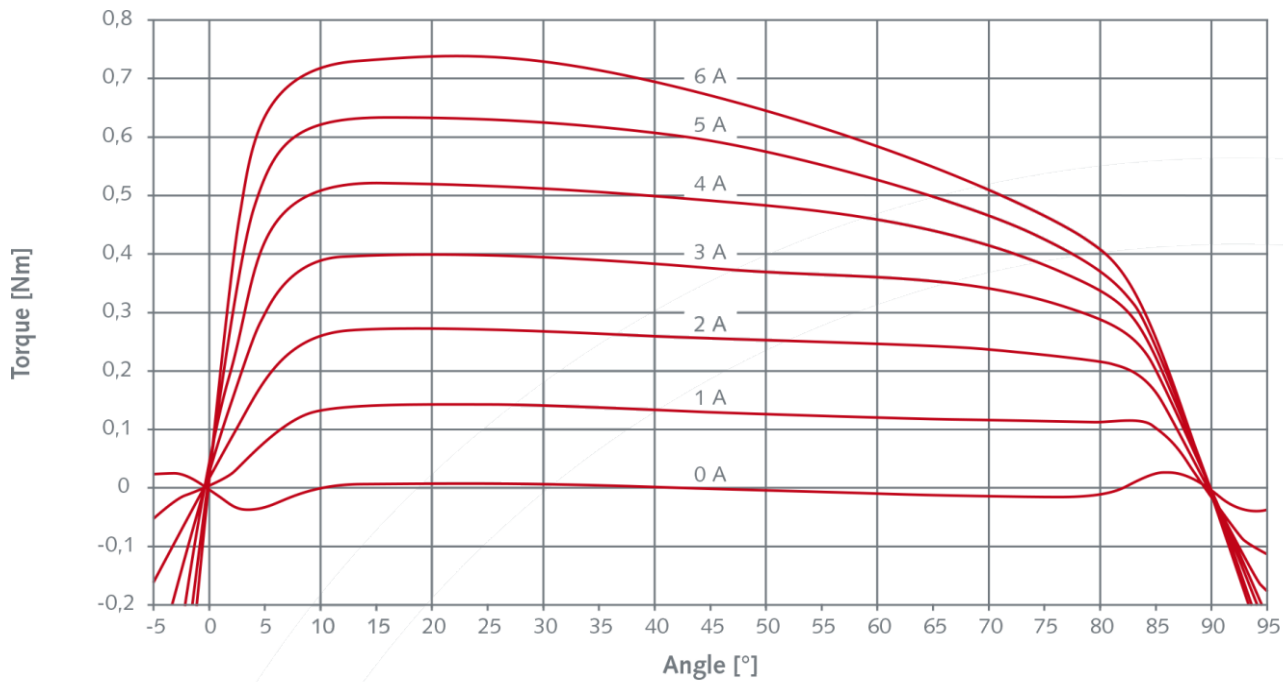

► Main Features

- Compact, robust, contactless
- Single phase DC operation (H-bridge compatible)
- Nominal torque proportional to current, bi-directional
- High peak torque
- Programmable contactless position sensor
- Integration of fail-safe optional
- Waterproof design optional

► Operating conditions

Qualified for on-engine applications:

Ambient temperature: -40 ... > +160° C
 Vibrations: 40 g